

# Genie®



## **Operator's Manual** *with Maintenance Information*

Second Edition  
First Printing  
Part No. 82799

**DPL™-25S**  
**DPL™-30S**  
**DPL™-35S**

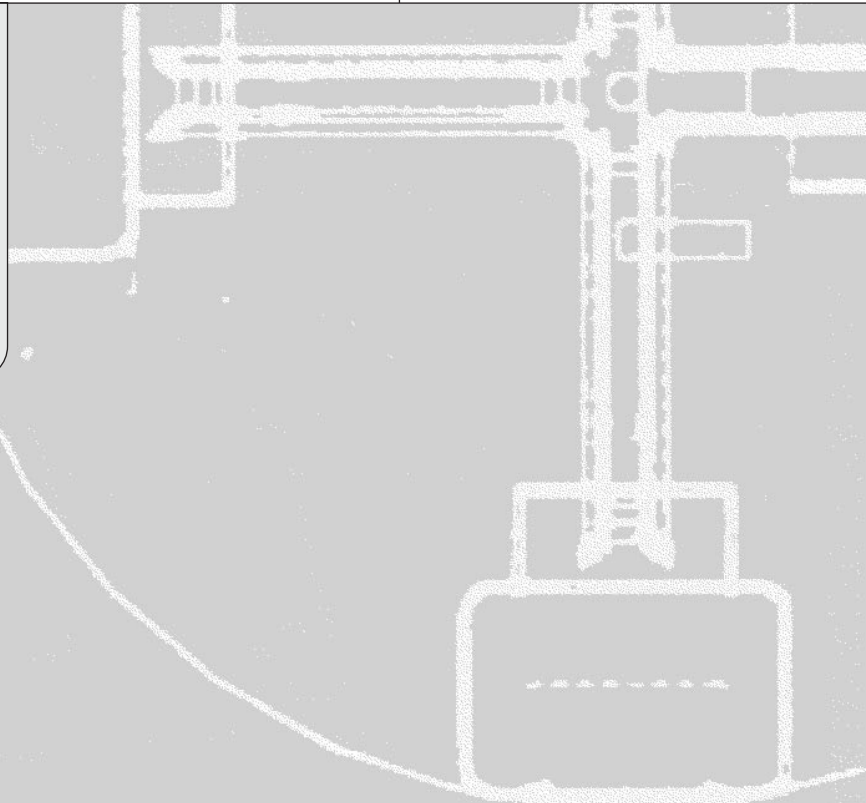

---

## Important

Read, understand and obey these safety rules and operating instructions before operating this machine. Only trained and authorized personnel shall be permitted to operate this machine. This manual should be considered a permanent part of your machine and should remain with the machine at all times. If you have any questions, call Genie Industries.

---

## Contents

	Page
Safety Rules .....	1
Controls .....	7
Legend .....	8
Pre-operation Inspection .....	9
Maintenance .....	11
Function Tests .....	14
Workplace Inspection .....	17
Operating Instructions .....	18
Battery and Charger Instructions .....	21
Transport and Lifting Instructions .....	22
Decals .....	24
Specifications .....	28

---

## Contact us:

Internet: <http://www.genieindustries.com>  
 e-mail: [techpub@genieind.com](mailto:techpub@genieind.com)

---

Copyright © 1996 by Genie Industries

First Edition: Fifth Printing, April 2002

Second Edition: First Printing, November 2003

"Genie" and "DPL" are registered trademarks of Genie Industries in the USA and many other countries. "Super Series" is a trademark of Genie Industries.

This machine complies with  
 ANSI/SIA 92.3-1990.

 Printed on recycled paper

Printed in U.S.A.

---

# Safety Rules



---

## Danger

Failure to obey the instructions and safety rules in this manual will cause death or serious injury.

---

## Do Not Operate Unless:

- You learn and practice the principles of safe machine operation contained in this operator's manual.
  - 1 Avoid hazardous situations.**
    - Know and understand the safety rules before going on to the next section.**
    - 2 Always perform a pre-operation inspection.
    - 3 Always perform the function tests prior to use.
    - 4 Inspect the workplace.
    - 5 Only use the machine as it was intended.
- You read, understand and obey the manufacturer's instructions and safety rules—safety and operator's manuals and machine decals.
- You read, understand and obey employer's safety rules and worksite regulations.
- You read, understand and obey all applicable governmental regulations.
- You are properly trained to safely operate the machine.
- The first time this machine is set up for use, a breather cap is installed. See Pre-operation Inspection section for breather cap instructions.

SAFETY RULES

**Tip-over Hazards**



Do not raise the platform unless the base is level, all four outriggers are properly set up and the leveling jacks firmly contact the ground.

Do not move the machine while the platform is raised.

Do not adjust or remove the outriggers while the platform is occupied or raised.

Do not place or attach overhanging loads to any part of this machine.

Do not transport tools and materials unless they are evenly distributed and can be safely handled by person(s) in the platform.



Do not raise the platform unless the machine is level. Do not set the machine up on a surface where it cannot be leveled using only the outriggers.

Do not place ladders or scaffolds in the platform or against any part of this machine.

Do not push off or pull toward any object outside the platform.

<b>Maximum allowable manual force</b>	90 lbs	400 N
---------------------------------------	--------	-------

Do not use the machine on a moving or mobile surface or vehicle.

Do not operate the machine in strong or gusty winds. Do not increase the surface area of the platform or the load. Increasing the area exposed to the wind will decrease machine stability.

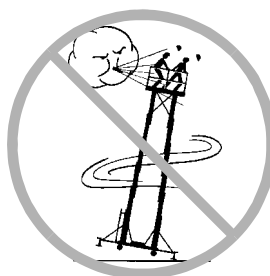

Occupants, equipment and materials shall not exceed the maximum platform capacity.

**Maximum capacity - DPL-25S**

ANSI and CE	750 lbs	340 kg
CSA	600 lbs	272 kg
Maximum occupants	2	

**Maximum capacity - DPL-30S**

ANSI and CE	750 lbs	340 kg
CSA	600 lbs	272 kg
Maximum occupants	2	

SAFETY RULES

**Maximum capacity - DPL-35S**

ANSI and CE	600 lbs	272 kg
CSA	500 lbs	227 kg
Maximum occupants	2	

Do not operate the machine near drop-offs, holes, bumps, debris, unstable or slippery surfaces or other possible hazardous conditions.

Do not alter or disable machine components that in any way affect safety and stability.

Do not replace items critical to stability with items of different weight or specification. Use only Genie authorized replacement parts.

When moving the machine with a forklift or other transport vehicle, the platform should be fully lowered, the guard rails should be down, the machine should be turned off and no personnel shall remain in the platform.

Do not modify or alter an aerial work platform without prior written permission from the manufacturer. Mounting attachments for holding tools or other materials onto the platform, toeboards or guard rail system can increase the weight in the platform and the surface area of the platform or the load.

**Fall Hazards**

The guard rail system provides fall protection. If occupants of the platform are required to wear personal fall protection equipment (PFPE) due to job site or employer rules, PFPE equipment and its use shall be in accordance with the PFPE manufacturer's instructions and applicable governmental requirements.



Do not sit, stand or climb on the platform guard rails. Maintain a firm footing on the platform floor at all times.

Do not enter or raise the platform unless the platform side guard rails are locked upright and the platform end guard rail and the platform entry gate are closed and latched.

Do not exit the platform while raised. If a power failure occurs, have ground personnel activate the manual lowering valve.

Keep the platform floor clear of debris.

## SAFETY RULES

## Electrocution Hazards

This machine is not electrically insulated and will not provide protection from contact with or proximity to electrical current.

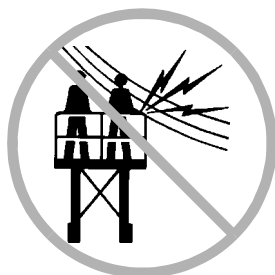

Keep away from the machine if it contacts energized power lines or becomes electrically charged. Personnel on the ground or in the platform must not touch or operate the machine until the energized power lines are shut off.

Maintain safe distances from electrical power lines and apparatus in accordance with applicable governmental regulations and the following chart.

Voltage Phase to Phase	Minimum Safe Approach Distance	
	Feet	Meters
0 to 300V	Avoid Contact	
300V to 50KV	10	3.05
50KV to 200KV	15	4.60
200KV to 350KV	20	6.10
350KV to 500KV	25	7.62
500KV to 750KV	35	10.67
750KV to 1000KV	45	13.72

Allow for platform movement, electrical line sway or sag and movement due to strong or gusty winds.

Do not use the machine as a ground for welding.

Do not operate the machine during lightning or storms.

Do not operate an AC powered machine or a DC battery charger unless using a 3-wire grounded extension cord connected to a grounded AC circuit. Do not alter or disable the 3-wire grounded plugs.

## Collision Hazards

Operators must comply with employer, job site and governmental rules regarding the use of personal protective equipment.

Check the work area for overhead obstructions or other possible hazards.

Be aware of crushing hazards when grasping the platform side guard rails.

Do not lower the platform unless the area below is clear of personnel and obstructions.

Be careful when transporting on an incline.

Stay clear of descending platform.

## Component Damage Hazards

Do not operate the machine unless a breather cap has been installed in the hydraulic reservoir. See the Pre-operation Inspection section for breather cap instructions.

Do not use the machine as an electrical ground for welding.

DC models: Do not operate the machine with a weak or overly discharged battery.

## SAFETY RULES

## Improper Use Hazard

Do not leave the machine unattended unless the key is removed to secure from unauthorized use.

## Damaged Machine Hazards

Do not use a damaged or malfunctioning machine.

Conduct a thorough pre-operation inspection of the machine and test all functions before each work shift. Immediately tag and remove from service a damaged or malfunctioning machine.

Be sure all maintenance has been performed as specified in this manual and the *Genie DPL Service Manual*.

Be sure all decals are in place and legible.

Be sure the operator's, safety and responsibilities manuals are complete, legible and in the storage container located in the platform.

## Bodily Injury Hazard

Do not operate the machine with a hydraulic oil or air leak. An air leak or hydraulic leak can penetrate and/or burn skin.

Improper contact with components under any cover will cause serious injury. Only trained maintenance personnel should access compartments. Access by the operator is only advised when performing a pre-operation inspection. All compartments must remain closed and secured during operation.

## Decal Legend

Genie product decals use symbols, color coding and signal words to identify the following:



Safety alert symbol—used to alert personnel to potential personal injury hazards. Obey all safety messages that follow this symbol to avoid possible injury or death.



Red—used to indicate the presence of an imminently hazardous situation which, if not avoided, will result in death or serious injury.



Orange—used to indicate the presence of a potentially hazardous situation which, if not avoided, could result in death or serious injury.



Yellow with safety alert symbol—used to indicate the presence of a potentially hazardous situation which, if not avoided, may cause minor or moderate injury.



Yellow without safety alert symbol—used to indicate the presence of a potentially hazardous situation which, if not avoided, may result in property damage.



Green—used to indicate operation or maintenance information.

## SAFETY RULES

## Battery and Charger Safety - DC Models

---

### Burn Hazards

Batteries contain acid. Always wear protective clothing and eye wear when working with batteries.



Avoid spilling or contacting battery acid. Neutralize battery acid spills with baking soda and water.

### Explosion Hazards



Batteries emit explosive gas. Keep sparks, flames and lighted tobacco away from the battery.

Charge the battery in a well-ventilated area.

Do not disconnect the charger DC output wires from the battery when the charger is on.

The sliding door on the base cover must remain open during the entire charging cycle.

### Electrocution Hazards



Connect the charger to a grounded AC circuit only.

Do not expose the battery or the charger to water or rain.

Before each use, inspect for damage. Replace damaged items before operating.

### Lifting Hazard

The battery weighs 105 lbs / 48 kg. Use the appropriate number of people and proper lifting techniques when lifting the battery.



# Controls

## Ground Controls

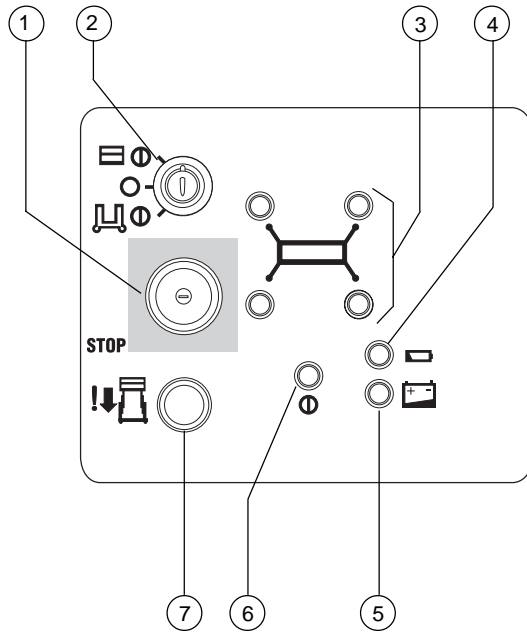

## Platform Controls

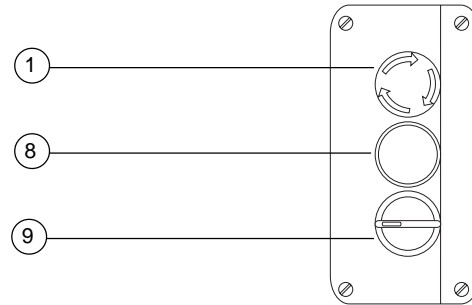

- 1 Red Emergency Stop button
- 2 Key switch
- 3 Outrigger interlock display lights (four)
- 4 Low battery indicator light for auxiliary lowering

- 5 DC models: Low battery indicator light
- 6 Power light
- 7 Auxiliary platform lowering button
- 8 Control activate button
- 9 Up/Down switch

# Legend

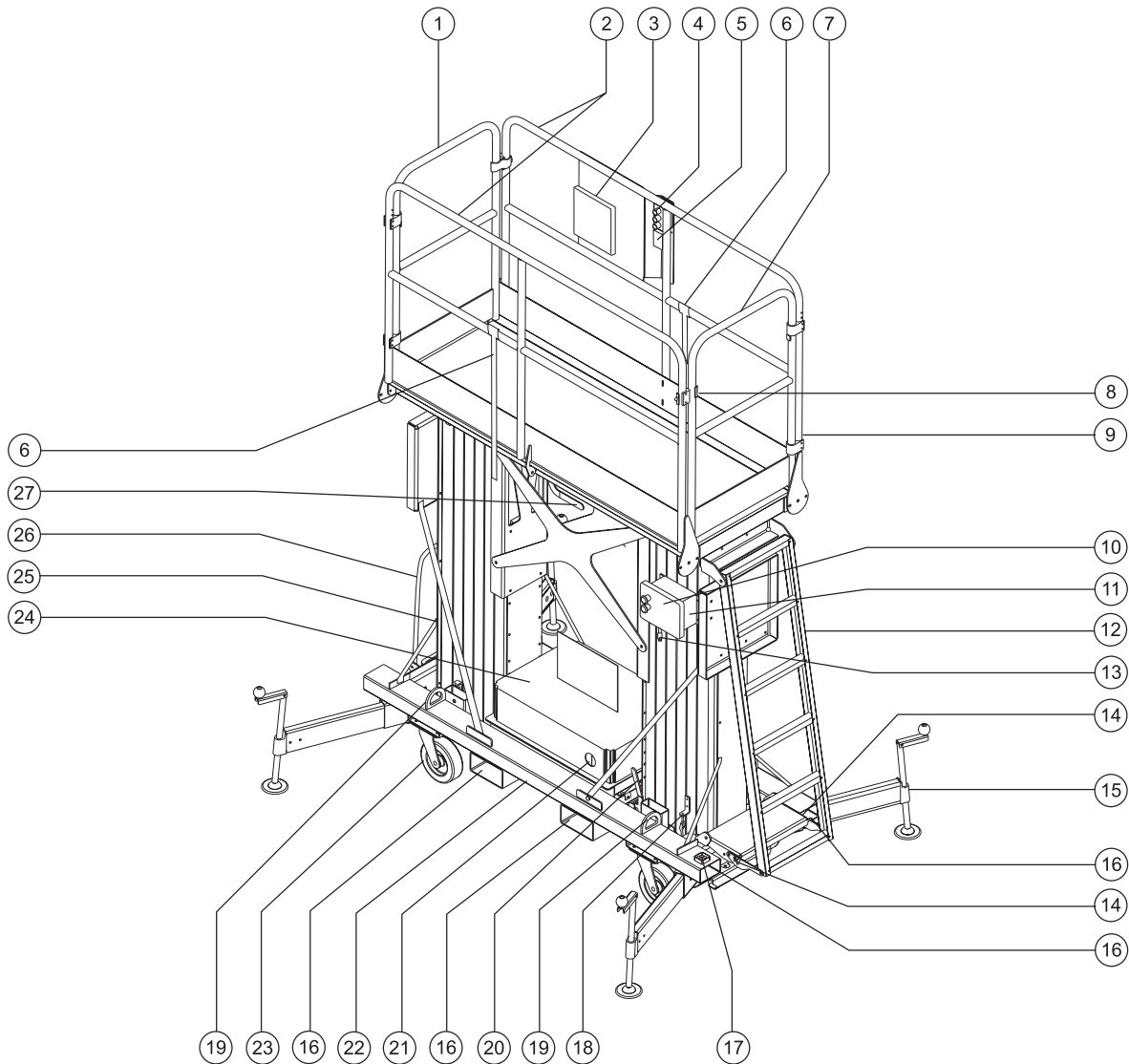

- |                            |  |                                       |
|----------------------------|--|---------------------------------------|
| 1 Platform end guard rail  | 11 AC models: Circuit breaker          | 19 Transport tie-down                 |
| 2 Platform side guard rail | 12 Platform entry ladder               | 20 Manual lowering lever              |
| 3 Manual storage container | 13 AC models: Power supply for machine | 21 Battery charger plug-in            |
| 4 Platform controls        | DC models: AC power to platform        | 22 Base                               |
| 5 AC outlet                | 14 Platform entry ladder lock pin      | 23 Caster with swivel lock            |
| 6 Guard rail lifting arm   | 15 Outrigger with leveling jack        | 24 Base cover                         |
| 7 Platform entry gate      | 16 Forklift pocket                     | 25 Mast                               |
| 8 Platform end gate latch  | 17 Bubble level                        | 26 Steer handle                       |
| 9 Platform                 | 18 Sequencing cable                    | 27 Platform guard rail locking handle |
| 10 Interlock display       |  |                                       |

# Pre-operation Inspection



## Do Not Operate Unless:

- You learn and practice the principles of safe machine operation contained in this operator's manual.
  - 1 Avoid hazardous situations.
  - 2 Always perform a pre-operation inspection.**
  - Know and understand the pre-operation inspection before going on to the next section.**
  - 3 Always perform the function tests prior to use.
  - 4 Inspect the workplace.
  - 5 Only use the machine as it was intended.

## Breather Cap - AC & DC Models

Component damage will occur if the machine is operated without a breather cap.

The first time this machine is set up for use, the pipe plug in the hydraulic reservoir, under the battery cover, must be removed and permanently replaced with a breather cap.

A breather cap is supplied and can be found in an envelope taped to the mast.

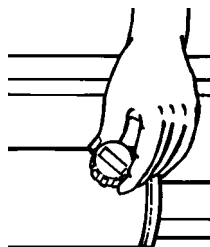

## Fundamentals

It is the responsibility of the operator to perform a pre-operation inspection and routine maintenance.

The pre-operation inspection is a visual inspection performed by the operator prior to each work shift. The inspection is designed to discover if anything is apparently wrong with a machine before the operator performs the function tests.

The pre-operation inspection also serves to determine if routine maintenance procedures are required. Only routine maintenance items specified in this manual may be performed by the operator.

Refer to the list on the next page and check each of the items.

If damage or any unauthorized variation from factory delivered condition is discovered, the machine must be tagged and removed from service.

Repairs to the machine may only be made by a qualified service technician, according to the manufacturer's specifications. After repairs are completed, the operator must perform a pre-operation inspection again before going on to the function tests.

Scheduled maintenance inspections shall be performed by qualified service technicians, according to the manufacturer's specifications and the requirements listed in the responsibilities manual.

## PRE-OPERATION INSPECTION

## Pre-operation Inspection

---

- Be sure that the operator's, safety and responsibilities manuals are complete, legible and in the storage container located in the platform.
- Be sure that all decals are legible and in place. See Decals section.
- Check for battery fluid leaks and proper fluid level. Add distilled water if needed. See Maintenance section.
- Check for hydraulic oil leaks and proper oil level. Add oil if needed. See Maintenance section.

Check the following components or areas for damage, improperly installed or missing parts and unauthorized modifications:

- Electrical components and wiring
- Coil cord (if equipped)
- Hydraulic power unit, hoses, fittings and cylinders
- Manual lowering lever
- Platform end guard rail, platform side guard rails and platform entry gate
- Guard rail lock handles
- Sequencing cables and pulleys
- Lifting chains and idler wheels
- Nuts, bolts and other fasteners
- Mast and mast braces

- Breather cap
- Outriggers, leveling jacks and footpads
- Guard rail lift arm
- Platform entry ladder

Check entire machine for:

- Dents or damage
- Corrosion or oxidation
- Crack in welds or structural components
- Inspect and clean battery terminals and all battery cable connections.
- Be sure that all structural and other critical components are present and all associated fasteners and pins are in place and properly tightened.

# Maintenance



## Observe and Obey:

- Only routine maintenance items specified in this manual shall be performed by the operator.
- Scheduled maintenance inspections shall be completed by qualified service technicians, according to the manufacturer's specifications and the requirements specified in the responsibilities manual.

## Maintenance Symbols Legend

### NOTICE

The following symbols have been used in this manual to help communicate the intent of the instructions. When one or more of the symbols appear at the beginning of a maintenance procedure, it conveys the meaning below.



Indicates that tools will be required to perform this procedure.



Indicates that new parts will be required to perform this procedure.

## MAINTENANCE

**Check the Battery - DC Models**

Proper battery condition is essential to good machine performance and safe operation. Improper fluid levels or damaged cables and connections can result in component damage and hazardous conditions.

**⚠ WARNING** Electrocution hazard. Contact with hot or live circuits could result in death or serious injury. Remove all rings, watches and other jewelry.

**⚠ WARNING** Bodily injury hazard. Batteries contain acid. Avoid spilling or contacting battery acid. Neutralize battery acid spills with baking soda and water.

**NOTICE** Perform this test after fully charging the batteries.

- 1 Put on protective clothing and eye wear.
- 2 Remove the battery vent caps.
- 3 Check the battery acid level. If needed, replenish with distilled water to the bottom of the battery fill tube. Do not overfill.
- 4 Install the vent caps.

**Check the Hydraulic Oil Level - AC and DC Models**

Maintaining the hydraulic oil at the proper level is essential to machine operation. Improper hydraulic oil levels can damage hydraulic components. Daily checks allow the inspector to identify changes in oil level that might indicate the presence of hydraulic system problems.

- 1 Be sure the platform is fully lowered.
  - 2 Check the sight gauge on the side of the hydraulic reservoir.
- ⦿ Result: The hydraulic oil level should be visible in the middle of the sight gauge. Do not overfill.

**Hydraulic oil specifications**

Hydraulic oil type	Chevron Rykon Premium MV equivalent
--------------------	--

## MAINTENANCE

**Scheduled Maintenance**

Maintenance performed quarterly, annually and every two years must be completed by a person trained and qualified to perform maintenance on this machine according to the procedures found in the service manual for this machine.

Machines that have been out of service for more than three months must receive the quarterly inspection before they are put back into service.

# Function Tests



---

## Do Not Operate Unless:

- ☑ You learn and practice the principles of safe machine operation contained in this operator's manual.
  - 1 Avoid hazardous situations.
  - 2 Always perform a pre-operation inspection.
  - 3 Always perform the function tests prior to use.**
- Know and understand the function tests before going on to the next section.**
  - 4 Inspect the workplace.
  - 5 Only use the machine as it was intended.

## Fundamentals

The function tests are designed to discover any malfunctions before the machine is put into service. The operator must follow the step-by-step instructions to test all machine functions.

A malfunctioning machine must never be used. If malfunctions are discovered, the machine must be tagged and removed from service. Repairs to the machine may only be made by a qualified service technician, according to the manufacturer's specifications.

After repairs are completed, the operator must perform a pre-operation inspection and function tests before putting the machine into service.

---

## Function Tests

- 1 Position the machine directly below the desired work area.
- 2 Connect to the appropriate power source:  
DC models: Connect the battery pack.  
AC models: Connect to a grounded 15A AC power supply. Use a 12 gauge / 3.3 mm<sup>2</sup> 3-wire grounded extension cord no longer than 50 feet / 13 m.
- 3 Insert the key and turn to platform control.
- 4 Pull out the red Emergency Stop button at the ground controls to the on position.
- ⦿ Result: The power light should come on.
- 5 Install each outrigger and adjust the leveling jacks to level the machine. Level the machine using only the outriggers.



FUNCTION TESTS

6 Be sure that all four interlock display lights at the ground controls are on.

7 Use the bubble level and adjust the leveling jacks until the machine base is level.

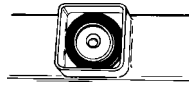

8 Rotate the platform guard rail locking handle and rotate the platform side guard rail to the upright position. Be sure the side guard rail locks in place. Repeat for the other side.

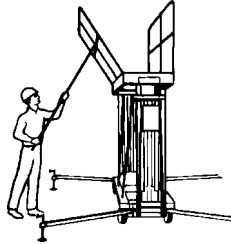

9 Pull the ladder lock pins and rotate the ladder down. Be sure the ladder locks in place.

10 Climb the ladder to enter the platform. Close and latch the platform entry gate and the platform end guard rail.

**Test Emergency Stop**

11 Twist to release the red Emergency Stop button at the platform controls.

12 Push in the red Emergency Stop button at the ground controls to the off position.

13 Push and hold the control activate button and rotate the up/down switch in the direction of intended travel.

⊙ Result: The up/down function should not operate.

14 Push in the red Emergency Stop button at the platform controls to the off position.

15 Pull out the red Emergency Stop button at the ground controls to the on position.

16 Push and hold the control activate button and rotate the up/down switch in the direction of intended travel.

⊙ Result: The up/down function should not operate.

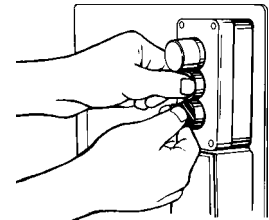

---

## FUNCTION TESTS

### Test Outrigger Interlock

- 17 Twist to release the red Emergency Stop button at the platform controls.
- 18 Push and hold the control activate button and rotate the up/down switch in the direction of intended travel.
  - ⊙ Result: The up/down function should operate.
- 19 Unscrew one leveling jack until the corresponding interlock display light turns off.
- 20 Push and hold the control activate button and rotate the up/down switch in the direction of intended travel.
  - ⊙ Result: The up/down function should not operate.
- 21 Return the leveling jack to the previous setting and check the bubble level.
- 22 Repeat the procedure for each outrigger.

### Test Auxiliary Platform Lowering - AC & DC Models

- 23 Raise the platform slightly.
- 24 Disconnect the power source from the machine.
- 25 Turn the key switch to ground control.
- 26 Push in the auxiliary platform lowering button at the ground controls.
  - ⊙ Result: The platform should lower.
- 27 Connect the power source to the machine.

- 28 Turn the key switch to platform control.
- 29 Raise the platform approximately 6 in / 15 cm.
- 30 Disconnect the power source from the machine.
- 31 Push and hold the control activate button and rotate the up/down switch in the down direction.
  - ⊙ Result: The platform should lower.
- 32 Connect the power source to the machine.

### Test Manual Lowering

- 33 Raise the platform slightly.
- 34 Activate the manual lowering lever.
  - ⊙ Result: The platform should lower.

# Workplace Inspection



---

## Do Not Operate Unless:

- You learn and practice the principles of safe machine operation contained in this operator's manual.

- 1 Avoid hazardous situations.
- 2 Always perform a pre-operation inspection.
- 3 Always perform function tests prior to use.

### 4 Inspect the workplace.

**Know and understand the workplace inspection before going on to the next section.**

- 5 Only use the machine as it was intended.

## Workplace Inspection

Be aware of and avoid the following hazardous situations:

- drop-offs or holes
- bumps, floor obstructions or debris
- slopes that exceed the machine's leveling capability
- unstable or slippery surfaces
- overhead obstructions and high voltage conductors
- hazardous locations
- inadequate surface support to withstand all load forces imposed by the machine
- wind and weather conditions
- the presence of unauthorized personnel
- other possible unsafe conditions

## Fundamentals

The workplace inspection helps the operator determine if the workplace is suitable for safe machine operation. It should be performed by the operator prior to moving the machine to the workplace.

It is the operator's responsibility to read and remember the workplace hazards, then watch for and avoid them while moving, setting up and operating the machine.

---

# Operating Instructions



---

## Do Not Operate Unless:

- You learn and practice the principles of safe machine operation contained in this operator's manual.
  - 1 Avoid hazardous situations.
  - 2 Always perform a pre-operation inspection.
  - 3 Always perform function tests prior to use.
  - 4 Inspect the workplace.
  - 5 Only use the machine as it was intended.**

## Fundamentals

The Operating Instructions section provides instructions for each aspect of machine operation. It is the operator's responsibility to follow all the safety rules and instructions in the operator's, safety and responsibilities manuals.

Using the machine for anything other than lifting personnel, along with their tools and materials, to an aerial work site is unsafe and dangerous.

Only trained and authorized personnel should be permitted to operate a machine. If more than one operator is expected to use a machine at different times in the same work shift, they must all be qualified operators and are all expected to follow all safety rules and instructions in the operator's, safety and responsibilities manuals. That means every new operator should perform a pre-operation inspection, function tests, and a workplace inspection before using the machine.

## OPERATING INSTRUCTIONS

## Setup

- 1 Position the machine directly below the desired work area.
- 2 Connect to an appropriate power source:  
DC models: Connect the battery pack.  
AC models: Connect to a grounded 15A AC power supply. Use a 12 gauge / 3.3 mm<sup>2</sup> 3-wire grounded extension cord no longer than 50 feet / 13 m.
- 3 Insert the key and turn to platform control.
- 4 Pull out the red Emergency Stop button at the ground controls to the on position. Be sure the power light is on.
- 5 Install the outriggers and adjust the leveling jacks to level the machine. Use the bubble level to be sure the machine is level.
- 6 Be sure that all four interlock display lights at the ground controls are on.
- 7 Pull down on the platform guard rail locking handle and rotate the platform side guard rail to the upright position. Be sure the side guard rail locks in place. Repeat for the other side.
- 8 Pull the ladder lock pins and rotate the ladder down. Be sure the ladder locks in place.
- 9 Climb the ladder to enter the platform. Close and latch the platform entry gate and the platform end guard rail.

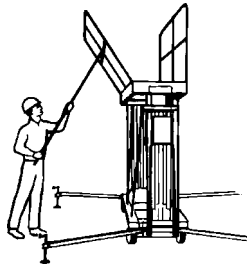

## Emergency Stop

- 1 Push in the red Emergency Stop button at the platform controls or at the ground controls to stop the up function.

## Platform Raise and Lower

- 1 Twist to release the red Emergency Stop button.
- 2 Push and hold the control activate button and rotate the up/down switch in the desired direction of travel.

## OPERATING INSTRUCTIONS

## Manual Lowering

- 1 Activate the manual lowering lever.

## Auxiliary Platform Lowering - AC & DC Models

- 1 Turn the key switch to ground control. Pull out the red Emergency Stop button to the on position.
- 2 Activate the auxiliary platform lowering button at the ground controls.

## Platform Overload Indicator Light (if equipped)



Light flashing indicates the platform is overloaded and no functions will operate. An alarm will sound at the platform controls.

The machine must be reset before functions will operate.

To reset the machine:

- 1 Remove load from the platform.
- 2 Push in, then twist to release the red Emergency Stop button at the platform controls.
- 3 Operate the machine. If the load in the platform is below the rated capacity, the machine will operate.

## Fall Protection

Personal fall protection equipment (PFPE) is not required when operating this machine. If PFPE is required by job site or employer rules, the following shall apply:

All PFPE must comply with applicable governmental regulations and must be inspected and used in accordance with the manufacturer's instructions.

## After Each Use

- 1 Select a safe storage location—firm, level surface, weather protected, clear of obstruction and traffic.
- 2 Remove the key to secure from unauthorized use.
- 3 DC models: Recharge the battery.

## OPERATING INSTRUCTIONS



## Battery and Charger Instructions

### Observe and Obey:

- ☑ Do not use an external charger or booster battery.
- ☑ Charge the battery in a well-ventilated area.
- ☑ Use the proper AC input voltage for charging as indicated on the charger.
- ☑ Use only Genie authorized battery and charger.

### To Charge Battery:

- 1 Slide open the battery cover to access the charger and the battery. The cover must remain open for the entire charging cycle.

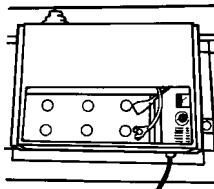

- 2 Remove the battery vent caps and check the battery acid level. If necessary, add only enough distilled water to cover the plates. Do not overfill prior to the charge cycle.
- 3 Install the battery vent caps.
- 4 Connect the battery charger to a grounded outlet of proper voltage and amperage as indicated on the battery charger.

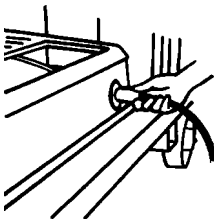

- 5 Set the timer based on the amount of use:
    - Light Use (less than 15 lifting cycles): Set to 7 hours.
    - Heavy Use (greater than 15 lifting cycles): Set to the on position.
  - 6 The charger will automatically shut off at the end of the set period.
- Note: If the ammeter drops to 3A or less within the first 15 minutes, the battery is fully charged.
- 7 Check the battery acid level when the charge cycle is complete. Replenish with distilled water to the bottom of the fill tube.

## Dry Battery Filling And Charging Instructions

- 1 Remove the battery vent caps and permanently remove the plastic seal from the battery vent openings.
- 2 Fill each cell with battery acid (electrolyte) until the level is sufficient to cover the plates.

Do not fill to the maximum level until the battery charge cycle is complete. Overfilling can cause battery acid to overflow during charging. Neutralize battery acid spills with baking soda and water.

- 3 Install the battery vent caps.
- 4 Charge the battery for seven hours or until the charger ammeter reads 3A or less.
- 5 Check the battery acid level when the charge cycle is complete. Fill with distilled water to the bottom of the fill tube.

# Transport and Lifting Instructions



## Observe and Obey:

- ☑ Common sense and planning must be applied to control the movement of the machine when lifting it with a crane or forklift.
- ☑ The transport vehicle must be parked on a level surface.
- ☑ The transport vehicle must be secured to prevent rolling while the machine is being loaded.
- ☑ Vehicle capacity, loading equipment and surfaces must be capable of supporting the machine weight. See the serial plate for the machine weight.
- ☑ The machine must be secured to the transport vehicle with chains or straps of ample load capacity.

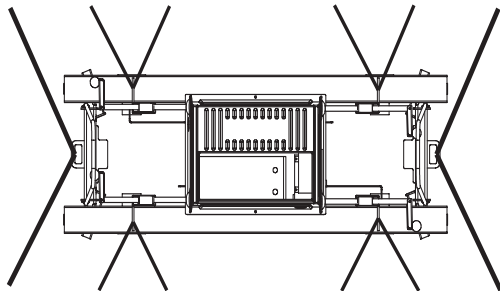

## Loading the Machine With a Forklift

- 1 Lower the platform.
- 2 Lower the platform side guard rails, the platform end guard rail and the platform entry gate. Secure the side guard rails with the tie-down strap.
- 3 Push in the red Emergency Stop buttons at the ground and platform controls, turn the key switch to the off position and remove the key.
- 4 Inspect the entire machine for loose or unsecured items.
- 5 Use the forklift pockets located on the sides of the machine.

## Winching the Machine onto a Flatbed Truck

- 1 Lower the platform.
- 2 Lower the platform side guard rails, the platform end guard rail and the platform entry gate. Secure the side guard rails with the tie-down strap.
- 3 Push in the red Emergency Stop buttons at the ground and platform controls, turn the key switch to the off position and remove the key.
- 4 Inspect the entire machine for loose or unsecured items.
- 5 Connect the cable to the winching point (tie-down points) located on the base.
- 6 Carefully winch the machine onto the truck.
- 7 Secure the machine base and masts to the transport vehicle. Use chains or straps of ample load capacity.



TRANSPORT AND LIFTING INSTRUCTIONS



**Observe and Obey:**

- ☑ Only qualified riggers should rig and lift the machine.
- ☑ Be sure the crane capacity, loading surfaces and straps or lines are sufficient to withstand the machine weight. See the serial plate for the machine weight.

**Lifting Instructions**

Fully lower the platform. Be sure the controls and covers are secure. Remove all loose items on the machine.

Determine the center of gravity of your machine using the table and the picture on this page.

Attach the rigging only to the designated lifting points on the machine. There are two lifting points on each side of the machine.

Adjust the rigging to prevent damage to the machine and to keep the machine level.

Center of gravity	X Axis	Y Axis	Z Axis
<b>DPL-25</b>	40.5 in 1.03 m	13.15 in 34.3 cm	32.9 in 83.6 cm
<b>DPL-30</b>	40.5 in 1.03 m	13.15 in 34.3 cm	33 in 83.8 cm
<b>DPL-35</b>	40.5 in 1.03 m	13.15 in 34.3 cm	33.11 in 84.1 cm

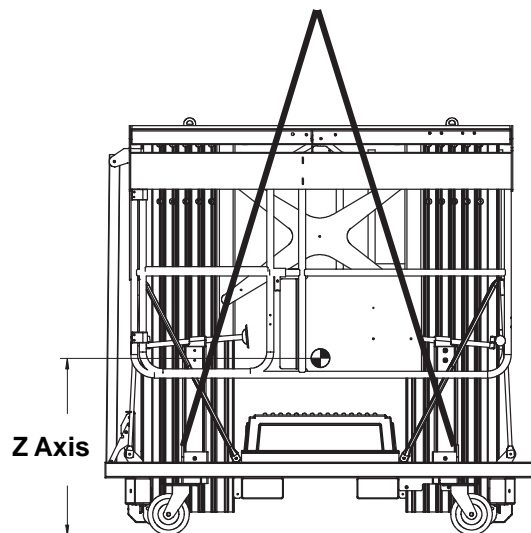
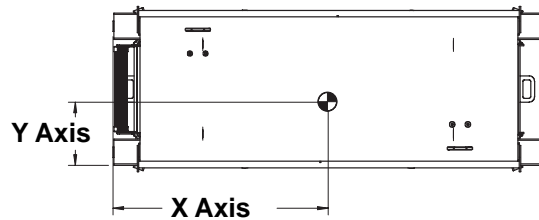

# Decals

## Inspection for Decals with Words

Determine whether the decals on your machine have words or symbols. Use the appropriate inspection to verify that all decals are legible and in place.

Part No.	Description	Quantity
27857	Caution - Component Damage	1
27865	Label - Bubble Level	2
27868	Danger - Tip-over, Relief	1
28174	Label - Power to Platform, 230V	2
28176	Notice - Missing Manuals	1
28235	Label - Power to Platform, 115V	2
28236	Warning - Failure To Read	1
37118	Warning - Bodily Injury Hazard	1
38142	Label - Circuit Breaker, AC models	1
40465	Notice - Manual Lowering Lever	1
40466	Danger - General Safety	2
40467	Notice - Operating Instructions, Ground	1
40468	Notice - Operating Instructions, Platform	1
40469	Danger - Tip-over/Fall Hazard	1
40514	Warning - Guard Rail Lock Handle	2
40515	Notice - Max Capacity 600 lbs / 272 kg, ANSI, CSA	1
40516	Danger/Notice - Battery Safety & Charger Instructions	1

Part No.	Description	Quantity
41216	Notice - Max Capacity 750 lbs / 340 kg, ANSI and CSA	1
41263	Notice - Max Capacity 500 lbs / 227 kg, ANSI and CSA	1
62050	Cosmetic - DPL-25S	2
62051	Cosmetic - DPL-30S	2
62052	Cosmetic - DPL-35S	2
62939	Cosmetic - Genie Logo	2
62940	Cosmetic - DPL Super Series Logo	2
82366	Label - Chevron Rykon	1
82783	Interlock Display - AC and DC Models	1
82802	Label - Control Activate	1
82992	Label - Wheel Load	4
82993	Label - Outrigger Load	4
97530	Notice - Maximum Manual Force	1

DECALS

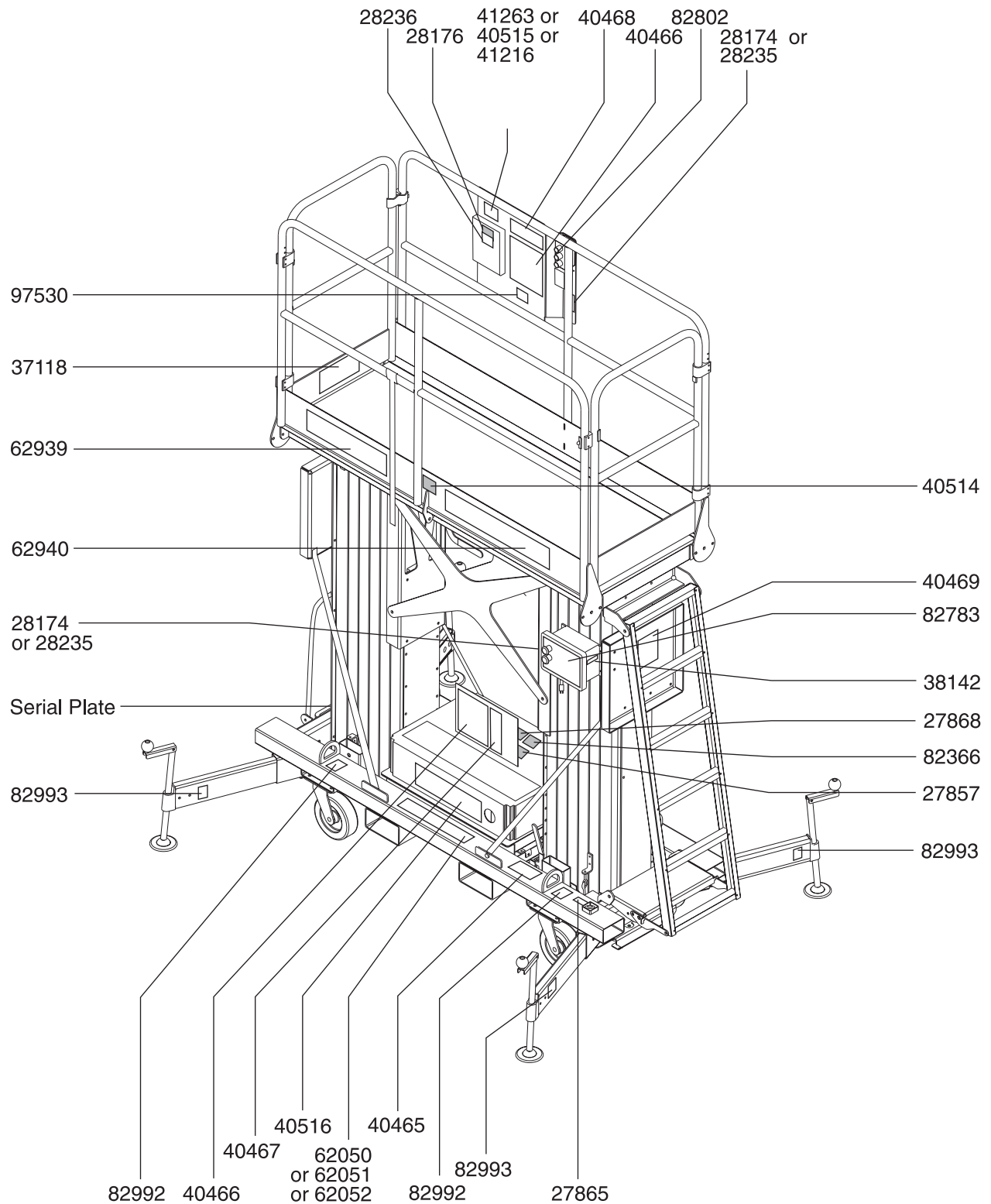

## DECALS

## Inspection for Decals with Symbols

Determine whether the decals on your machine have words or symbols. Use the appropriate inspection to verify that all decals are legible and in place.

Part No.	Description	Quantity
28174	Label - Power to Platform, 230V	2
28235	Label - Power to Platform, 115V	2
62050	Cosmetic - DPL-25S	2
62051	Cosmetic - DPL-30S	2
62052	Cosmetic - DPL-35S	2
62939	Cosmetic - Genie Logo	2
62940	Cosmetic - DPL Super Series Logo	2
82481	Danger - Battery Safety	1
82487	Label - Read the Manual	2
82783	Interlock Display - AC and DC Models	1
82801	Label - Manual Lowering Lever	1
82802	Label - Control Activate	1
82803	Danger - Max Capacity, 272 kg	1
82804	Danger - Max Capacity, 340 kg	1
82805	Danger - Maximum Manual Force	1
82806	Label - 51 cm Outriggers, CE	4
82807	Label - 66 cm Outriggers, CE	4
82879	Label - Platform Overload	1
82992	Label - Wheel Load	4
82993	Label - Outrigger Load	4

DECALS

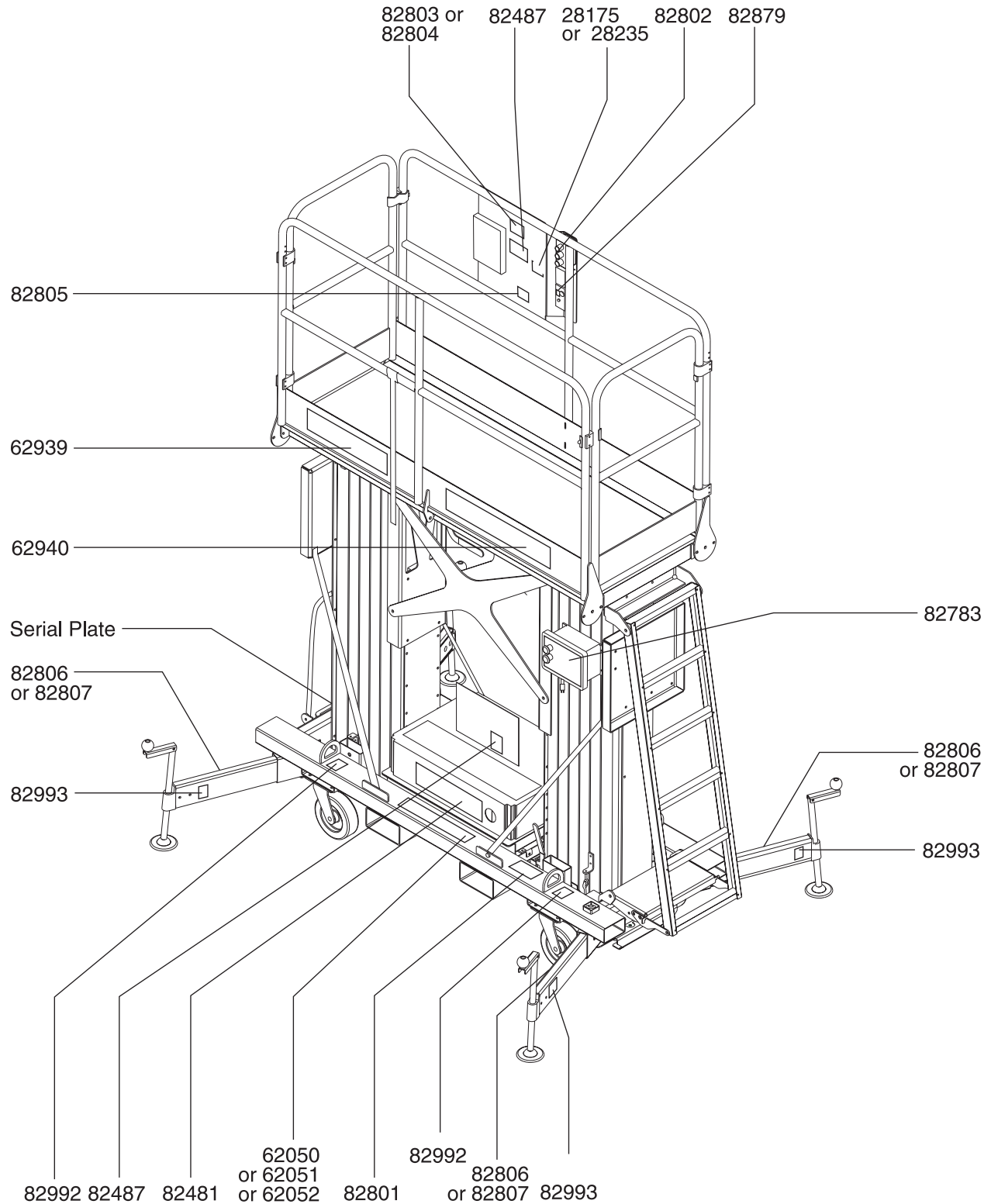

# Specifications

Model	DPL-25S	DPL-30S	DPL-35S
<b>Height, maximum working</b>	31 ft 4 in 9.5 m	36 ft 11 m	40 ft 9 in 12.4 m
<b>Height, maximum platform</b>	25 ft 4 in 7.7 m	30 ft 9.1 m	34 ft 9 in 10.6 m
<b>Height, guard rails stowed</b>	78 in 1.98 m	78 in 1.98 m	78 in 1.98 m
<b>Length, outriggers stowed</b>	81 <sup>3</sup> / <sub>4</sub> in 2.07 m	81 <sup>3</sup> / <sub>4</sub> in 2.07 m	81 <sup>3</sup> / <sub>4</sub> in 2.07 m
<b>Width, outriggers stowed</b>	31 <sup>1</sup> / <sub>2</sub> in 80 cm	31 <sup>1</sup> / <sub>2</sub> in 80 cm	31 <sup>1</sup> / <sub>2</sub> in 80 cm
<b>Outrigger footprint (l x w)</b>	84 x 60 in 2.1 x 1.5 m	89 x 73 in 2.3 x 1.9 m	89 x 73 in 2.3 x 1.9 m
<b>Platform dimensions (l x w)</b>	72 x 27 <sup>1</sup> / <sub>2</sub> in 1.83 m x 69.9 cm	72 x 27 <sup>1</sup> / <sub>2</sub> in 1.83 m x 69.9 cm	72 x 27 <sup>1</sup> / <sub>2</sub> in 1.83 m x 69.9 cm
<b>Power source</b>			
<b>AC</b>	220V or 115V	220V or 115V	220V or 115V
<b>DC</b>	12V	12V	12V
<b>Air power</b>	100 psi / 6.9 bar @ 80 cfm / 2.26 m <sup>3</sup> /min	100 psi / 6.9 bar @ 80 cfm / 2.26 m <sup>3</sup> /min	100 psi / 6.9 bar @ 80 cfm / 2.26 m <sup>3</sup> /min
<b>Weight</b> (Machine weights vary with option configurations)	See Serial Plate	See Serial Plate	See Serial Plate
<b>Maximum capacity</b>			
ANSI	750 lbs / 340 kg	750 lbs / 340 kg	600 lbs / 272 kg
CE	750 lbs / 340 kg	750 lbs / 340 kg	600 lbs / 272 kg
CSA	600 lbs / 272 kg	600 lbs / 272 kg	500 lbs / 227 kg
<b>Ambient operating temperature</b>	-20°F to 135°F -29°C to 57°C		
<b>Airborne noise emissions</b> Maximum sound level at normal operating workstations (A-weighted)	80 dB		
<b>Wheel load, maximum</b>	419 lbs	190 kg	
<b>Outrigger load, maximum</b>	581 lbs	264 kg	

**Continuous improvement of our products is a Genie policy. Product specifications are subject to change without notice or obligation.**

---

**Genie Scandinavia**  
**Phone** +46 31 3409612  
**Fax** +46 31 3409613

---

**Genie France**  
**Phone** +33 (0)2 37 26 09 99  
**Fax** +33 (0)2 37 26 09 98

---

**Genie Iberica**  
**Phone** +34 93 579 5042  
**Fax** +34 93 579 5059

---

**Genie Germany**  
**Phone** +49 (0)4202 88520  
**Fax** +49 (0)4202 8852-20

---

**Genie U.K.**  
**Phone** +44 (0)1476 584333  
**Fax** +44 (0)1476 584334

---

**Genie Mexico City**  
**Phone** +52 55 5666 5242  
**Fax** +52 55 5666 3241

---

**Genie North America**  
**Phone** 425.881.1800  
**Toll Free** USA and Canada  
800.536.1800  
**Fax** 425.883.3475

---

**Genie Australia Pty Ltd.**  
**Phone** +61 7 3375 1660  
**Fax** +61 7 3375 1002

---

**Genie China**  
**Phone** +86 21 53852570  
**Fax** +86 21 53852569

---

**Genie Malaysia**  
**Phone** +65 98 480 775  
**Fax** +65 67 533 544

---

**Genie Japan**  
**Phone** +81 3 3453 6082  
**Fax** +81 3 3453 6083

---

**Genie Korea**  
**Phone** +82 25 587 267  
**Fax** +82 25 583 910

---

**Genie Brasil**  
**Phone** +55 11 41 665 755  
**Fax** +55 11 41 665 754

---

**Genie Holland**  
**Phone** +31 10 220 7911  
**Fax** +31 10 220 6642

Distributed By: